

CHARACTERISTICS AND PERFORMANCE

Total weight unladen, with forks (kg)	4500
Maximum load capacity (kg)	2500
Maximum lift height (m)	5.9
Maximum forward reach (m)	3.3
Lift height at maximum load capacity (m)	4.7
Forward reach at maximum load capacity (m)	1.4
Load capacity at maximum height (kg)	1,750
Load capacity at maximum forward reach (kg)	1,000
Engine (make/number of cylinders)	Kubota/4
Tier 3 engine power (kW/HP)	55/75
Fuel capacity (l)	70
Maximum speed (kph)	36
Hydraulic system - Gear pump (bar-l/min)	210/80
Hydraulic oil capacity (l)	70
Electrical circuit (V)	12
Battery (Ah)	100
Cab compliant with ROPS/FOPS standards	●
Proportional mechanical joystick controls	●
Electro-mechanical joystick controls	○
Tac-Lock attachment coupling	●
Auxiliary boom hydraulic service	●
Two floating forks (1,200 mm long)	●
Hydrostatic transmission	●
Finger-Touch direction control	●
Inching Control pedal for minute-distance control	●
Permanent four-wheel drive	●
Four wheel steering	●
Service disk brakes on all wheels	●
Automatically locking parking brake	●
12-16.5 tyres	●
12/75-18 tyres	○
Rear differential lock	○
Four cab working lights (2 f. + 2 r.)	○
Manual air conditioning system	○
Roof window wiper	○
12 V electrical outlet on the boom head	○
Manual battery isolator	○
Front and roof sun shade	○
European farm tractor Type Approval	○

DIMENSIONS (mm)

A (mm)	3,900
B (mm)	835
C (mm)	2,450
D (mm)	615
E (mm)	3,480
F (mm)	270
H (mm)	1,800
M (mm)	995
P (mm)	1,920
R (mm)	3,370
S (mm)	4,200

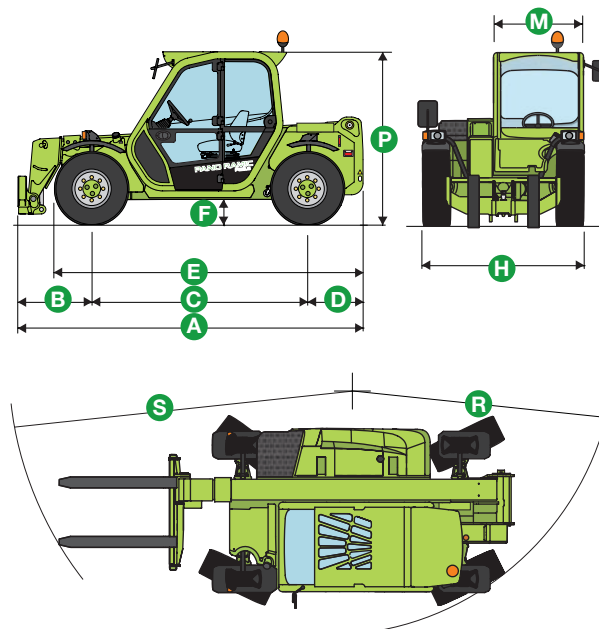

Performance figures refer to the machine equipped with forks.
 ● Standard. ○ Optional.

The telehandlers featured in this document may feature optional or special equipment which are not part of the standard equipment and are supplied upon request. Not all models or versions are available in all countries, due to regulatory restrictions. Information and technical data are those available at the time of printing. Merlo reserves the right to modify and update the contents of this document at any time without notice, following technological evolution. For further information on our products and services please contact your Merlo dealer.